

DEUBLIN

1129 Series Bearingless “Pop-Off” Rotating Unions for Coolant Service

- Single passage for coolant or MQL
- Patented “pop-off” technology allows unlimited dry running without media pressure
- Pop-off stroke of 0.7 - 3.0 mm compensates for thermal expansion of spindle during extended operation as well as variations in draw-bar position
- Full-flow design has no obstructions to trap swarf or debris
- Balanced mechanical seals made from silicon carbide for long life even under difficult operating conditions
- Anodised aluminium housing resists corrosion

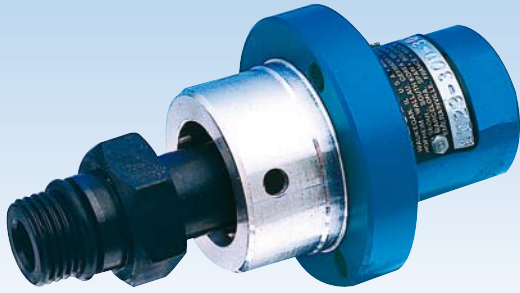

Operating Data

Media	Water-based Coolant MQL (oil mist) up to 10 bar (145 psi)		
Filtration	ISO 4406 Class 17/15/12, max. 60 micron		
Max. Speed	30.000 min ⁻¹	30,000 rpm	Standard
	46.000 min ⁻¹	46,000 rpm	High Pressure
Max. Pressure	140 bar	2,030 psi	
Max. Flow	24,3 l/min	6.4 gpm	
	1129-016-301	41,3 l/min	10.9 gpm
Max. Temperature	70°C	160°F	



**NO AIR PRESSURE
WITH ROTATION**

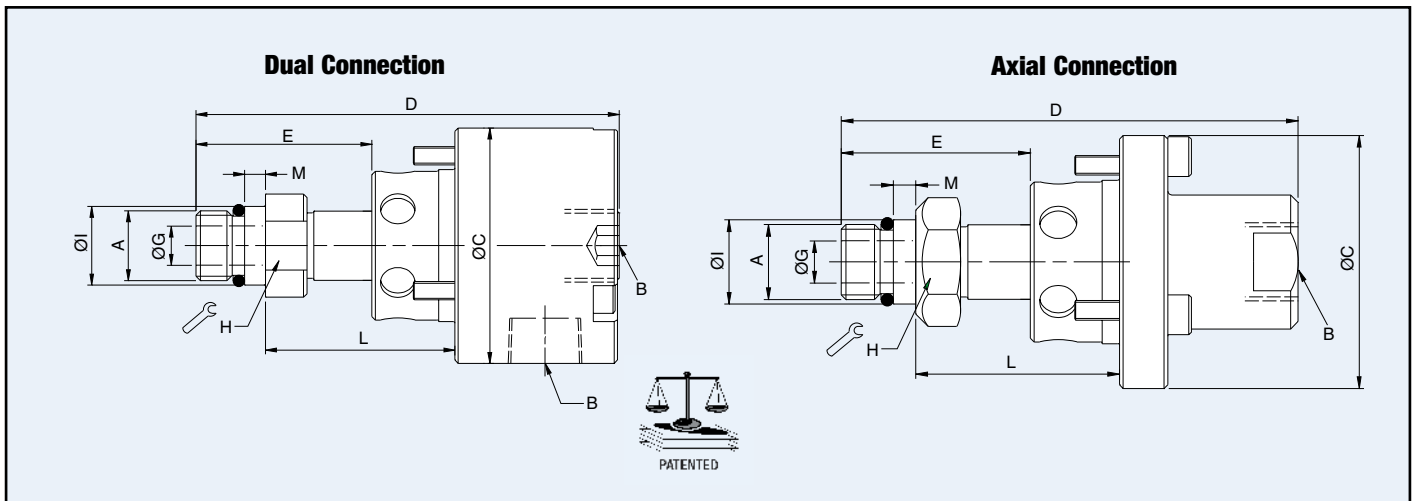
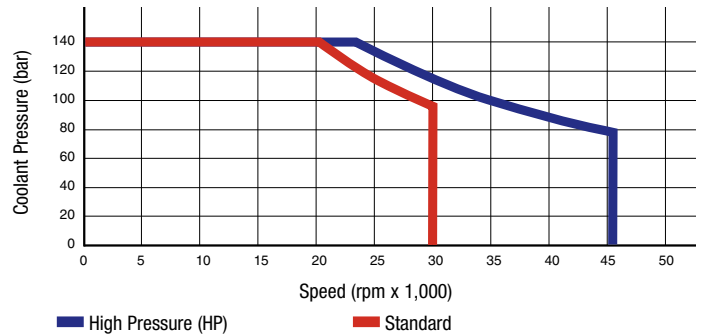

	Ordering Number	B Supply Connection	C Overall Diameter	D Overall Length	L Mounting Distance	A Rotor Connection	E Rotor Length	G Bore Diameter	H Across Flats	I Pilot Diameter	M Pilot Length	Max. Speed (rpm)		
Standard	Dual Connection	1129-033-301	3/8 PT	54	97	44.0 / 43.0	M16 x 1.5 LH	40	9	24	17.994 / 17.989	5	30,000	
		1129-033-327	3/8 PT	54	94	39.6 / 38.6	M12 x 1.25 LH	37	6	18	14.000 / 13.992	5	30,000	
		1129-050-301	3/8 PT	54	101	44.0 / 43.0	M16 x 1.5 LH	40	9	24	17.994 / 17.989	5	30,000	
		1129-859-731	G 3/8	54	106	39.2 / 38.8	M12 x 1.25 LH	37	5	18	14.000 / 13.992	5	30,000	
		Axial Connection	1129-016-301	3/8 PT	54	97	44.0 / 43.0	M16 x 1.5 LH	40	9	24	17.994 / 17.989	5	30,000
		1129-036-301	3/8 PT	54	98	44.0 / 43.0	M16 x 1.5 LH	40	9	24	17.994 / 17.989	5	30,000	
		1129-036-327	3/8 PT	54	94	39.6 / 38.6	M12 x 1.25 LH	37	6	18	14.000 / 13.992	5	30,000	
		1129-039-301	3/8 PT	54	97	44.0 / 43.0	M16 x 1.5 LH	40	9	24	17.994 / 17.989	5	30,000	
		1129-730-731	G 3/8	54	94	39.2 / 38.8	M12 x 1.25 LH	37	5	18	14.000 / 13.992	5	30,000	
		1129-927-929	G 3/8	54	101	39.2 / 38.8	M14 x 1.5 LH	37	7	24	14.494 / 14.486	5	30,000	
HP	1129-052-137	20 mm Counterbore	40	68	25	M12 x 1.25 LH	28	6	17	13.000 / 12.995	6	46,000		

DEUBLIN

1129 Series Bearingless "Controlled Leakage" Rotating Unions for Dry Air at High Speed

- Single passage for dry or lubricated air

Operating Data

Media	Air (dry or lubricated)	
Max. Speed	20.000 min ⁻¹	20,000 rpm
Max. Pressure	10 bar	145 psi
Max. Temperature	120°C	250°F

Bearingless Rotating Unions Available Configurations

DEUBLIN bearingless pop-off unions are available to fit virtually every machine tool in the world. Shown below are only some of the many configurations available from DEUBLIN.

Outboard Mounting

With outboard mounting, the union housing is installed from outside the spindle. Replacement is faster and easier with this mounting style.

Dual Port

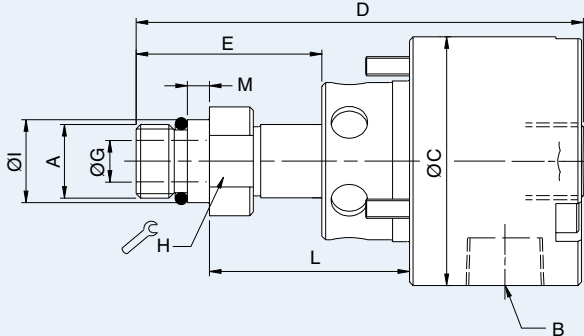

Axial Port

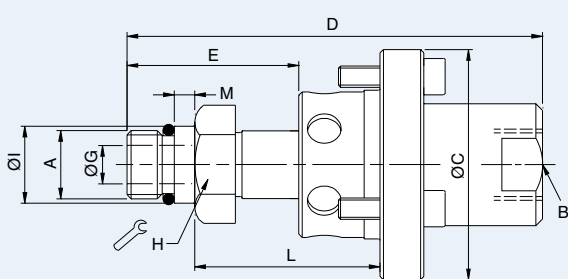

Inboard Mounting

With inboard mounting, the union housing is installed inside the spindle, typically within or near the tool clamping unit. Because a hose connection is not required, this mounting style can be very compact.

Counterbore

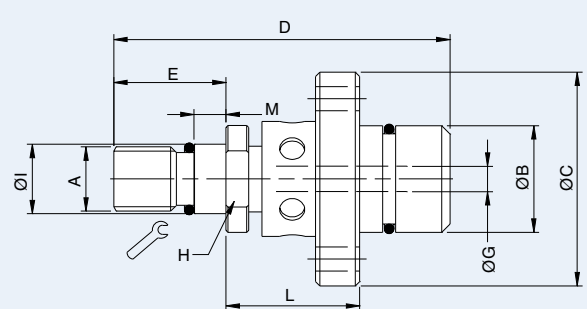

Threaded

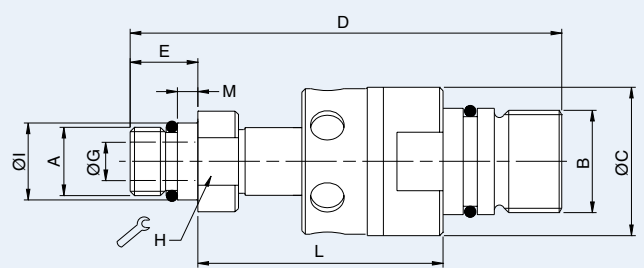

	Ordering Number	B Supply Connection	C Overall Diameter	D Overall Length	L Mounting Distance	A Rotor Connection	E Rotor Length	G Bore Diameter	H Across Flats	I Pilot Diameter	M Pilot Length	Max. Speed (rpm)
Axial Connection	1129-051-482	30 f7 Counterbore	48	72	40	M12 x 1 RH	33	6	17	12.992 / 12.982	6	20,000
	1129-490-489	30 f7 Counterbore	48	84	40.8 / 40.2	M12 x 1 RH	40	6	19	13.000 / 12.992	15	20,000
	1129-775	44 e8 Counterbore	44	63	38.5	12 e7	25	7	-	11.984 / 11.966	24	20,000