

# Shock and Vibration Switch VS2™ Series

The VS2 Series switches are shock-sensitive mechanisms for shutdown of engine or electric motor powered equipment. It is designed to detect shock/vibration in three planes of motion.

These fully adjustable switches use a magnetic latch to ensure reliable operation. Explosion-proof EX models for hazardous locations are available.

Ideal for use on engines, pumps, compressors, heat exchangers and pumping units, the VS2 Series can be used where shut-down protection from damaging shock/vibration is desired. Switches are field adjustable to the sensitivity required in each application.

## Specifications

**Normal Operating Temperature:** -40° to 185°F (-40° to 85°C); For UL and CSA applications, applicable temperature specification is de-rated to -40° to 140°F (-40° to 60°C)

### VS2 and VS2C

**Case:** Environmental Protection: Ingress protected to IP54 (when mounted on a horizontal surface with drain holes down). Suitable for non-hazardous areas. VS2C: C-clamp mount, includes 45 ft. (13.7 m) 2-conductor cable and 5 cable clamps

**Contacts:** SPDT-double make leaf contacts, 3A @ 240 VAC; 10A @120 VAC; 10A @ 32 VDC

**Shipping Weight:** VS2: 2 lb. 8 oz. (1.1 kg); VS2C: 7 lb (3.2 kg)

**Shipping Dimensions:** VS2: 8-1/4 x 9-1/4 x 5 in. (210 x 235 x 127 mm); VS2C: 12 x 7 x 5-1/2 in. (305 x 178 x 140 mm)

### VS2EX

**Case:** Base mount, explosion-proof aluminum alloy housing; meets IP54 specifications; Class I, Division 1, Groups C & D; UL and CSA listed

**Certification:** CSA, UL

**Snap switches:** 2-SPDT snap switches; 5A @ 480 VAC; 2A resistive, 1A inductive, up to 30 VDC

**Shipping Weight:** 4 lb. 8 oz. (2 kg)

**Shipping Dimensions:** 8-1/4 x 9-1/4 x 5 in. (210 x 235 x 127 mm)

### VS2EXR

**Case:** Same as VS2EX

**Certification:** CSA, UL

**Snap switch:** 1-SPDT snap switch and reset coil; 5A @ 480 VAC; 2A resistive, 1A inductive, up to 30 VDC

**Remote Reset:** 115 VAC or 24 VDC (specify)

**Shipping Weight:** 5 lb. 8 oz. (2.2 kg)

**Shipping Dimensions:** 8-1/4 x 9-1/4 x 5 in. (210 x 235 x 127 mm)

### VS2EXRB

**Case:** Explosion-proof aluminum alloy housing; designed to meet Class I, Division 1, Group B hazardous areas

**Certification:** No third-party certification

**Snap switch:** 1-SPDT snap switch with reset coil (option available for 2-SPDT switches); 5A @ 480 VAC; 2A resistive, 1A inductive, up to 30 VDC

**Remote Reset:** 115 VAC or 24 VDC (specify)

**Shipping Weight:** 17 lb. 8 oz. (7.9 kg)

**Shipping Dimensions:** 12 x 12 x 10 in. (305 x 305 x 254 mm)



\* Selected configurations are third-party listed.

## Basic Operation

Pushing the reset button moves the tripping latch into a magnetically held position. A shock/vibration will move the magnet beyond this holding position, thus freeing the spring loaded tripping latch to transfer the contacts and shut down the machinery (see dimensional diagrams or visual representation of parts).

## Remote Reset Operation (VS2EXR and VS2EXRB)

The remote reset option includes a built-in electric solenoid which allows reset of tripped unit from a remote location. Available for 115 VAC or 24 VDC.

# Dimensions

Environmental Protection: Ingress protected to IP54 (when mounted on a horizontal surface with drain holes down).

## VS2 and VS2C

The VS2 and VS2C are designed for use in non-hazardous locations. They have leaf type SPDT, double make contacts that can be used for shutdown and/or alarm. They have a slotted sensitivity adjustment located on the side of the case (see drawing).

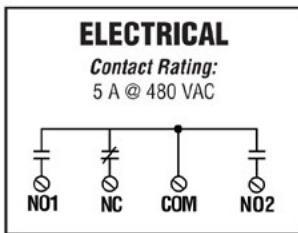
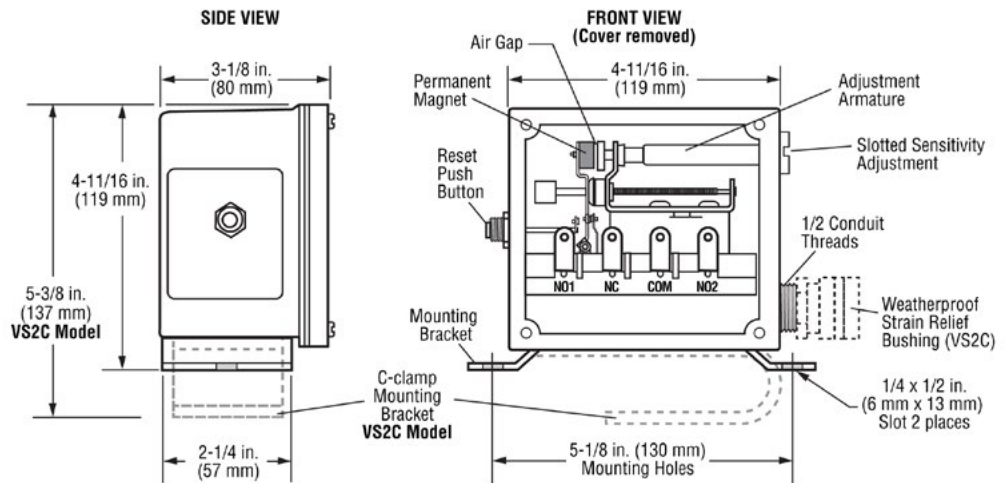

## VS2EX

- IP54 Specifications
- Snap switch Contacts
- Tattletale® Reset Button

Model VS2EX is housed in an explosion-proof enclosure with threaded cover. This enclosure is CSA and UL listed for Class I, Division 1, Groups C & D hazardous locations. In place of the leaf type contacts, 2-SPDT snap-switches are used in this model. Sensitivity is externally adjustable, and when tripped, the VS2EX gives a Tattletale indication on the reset button. It is constructed to meet IP54 specifications.

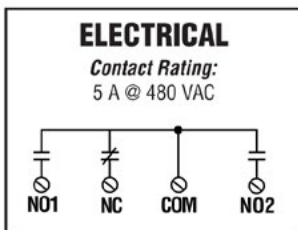
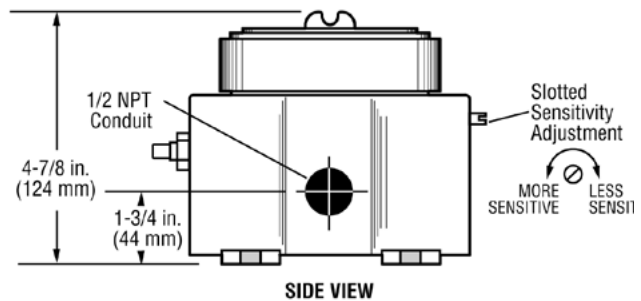
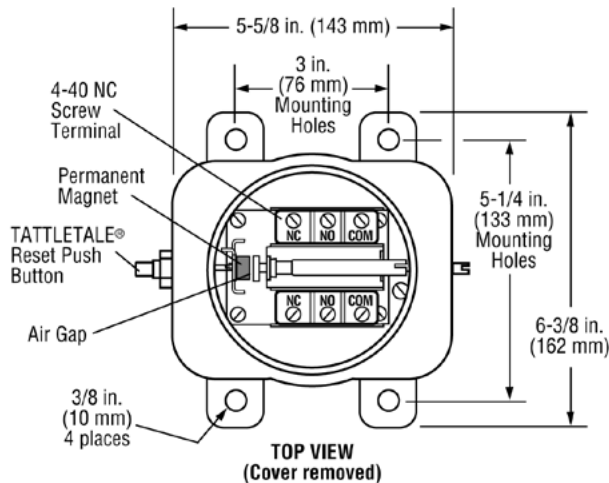

## Dimensions - continued

### VS2EXR

- Remote Reset Feature
- IP54 Specifications
- Snap-switch Contacts
- Tattletale® Reset Button

Model VS2EXR features an electric remote reset feature in addition to the Tattletale reset button. The VS2EXR uses only one SPDT snap-switch and is CSA and UL listed for Class I, Division 1, Groups C & D hazardous locations. It is constructed to meet IP54 specifications.



#### ELECTRICAL

##### Contact Rating:

5 A @ 125-480 VAC  
 1/2 A @ 125 VDC  
 1/4 A @ 250 VDC  
 2 A Resistive 30 VDC  
 1 A Inductive 30 VDC

##### Remote Reset Rating:

115 VAC or 24 VDC (Specify)  
 350 mA AC/DC

#### Remote Reset

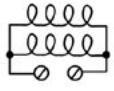

#### SPDT Snap-switch

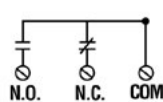

##### Option SPDT Snap-switch (DPDT)

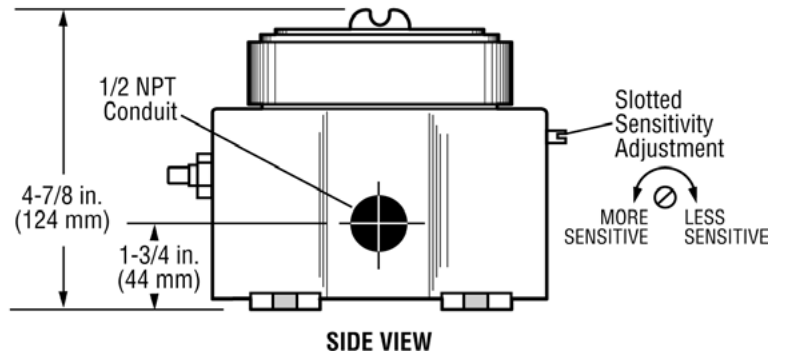
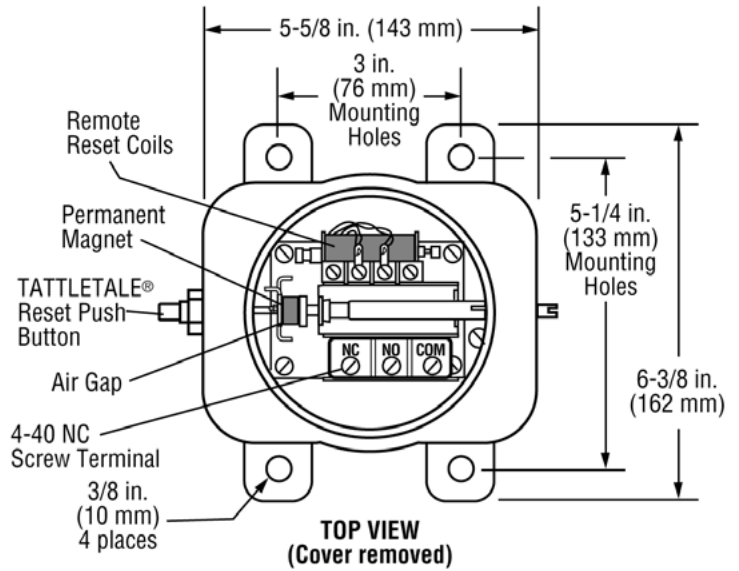
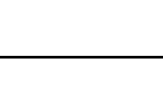

### VS2EXRB

- For Group B Locations (not certified)
- Snap-switch Contacts
- DPDT Feature Optional

Model VS2EXRB is constructed for use in Class I, Division 1, Group B, hazardous locations. It has as standard a SPDT snap-switch and an electric remote reset. Option is available for DPDT snap-switch

#### ELECTRICAL

##### Contact Rating:

5 A @ 125-480 VAC  
 1/2 A @ 125 VDC  
 1/4 A @ 250 VDC  
 2 A Resistive 30 VDC  
 1 A Inductive 30 VDC

##### Remote Reset Rating:

115 VAC or 24 VDC (Specify)  
 350 mA AC/DC

#### Remote Reset

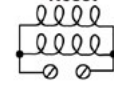

#### SPDT Snap-switch

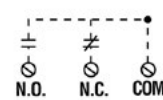
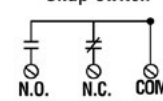

#### Option SPDT Snap-switch (DPDT)

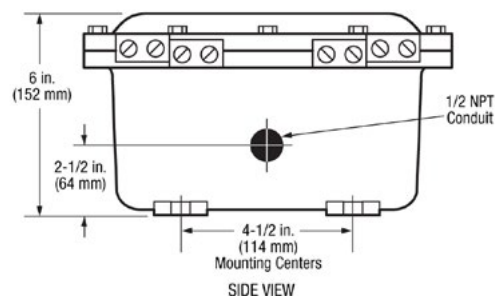
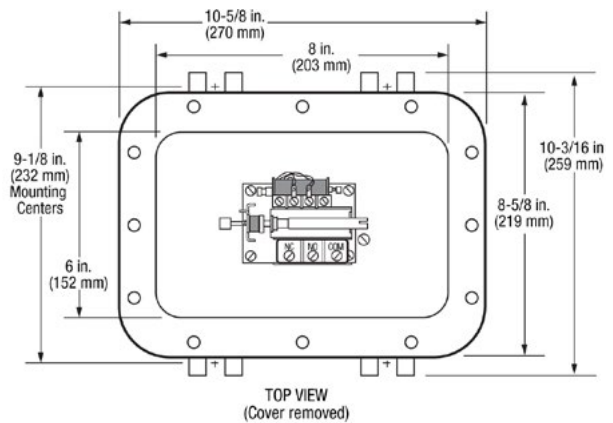

# How to Order

Options listed below. All configurations may not be available. Call your sales representative or Enovation Controls for more information.

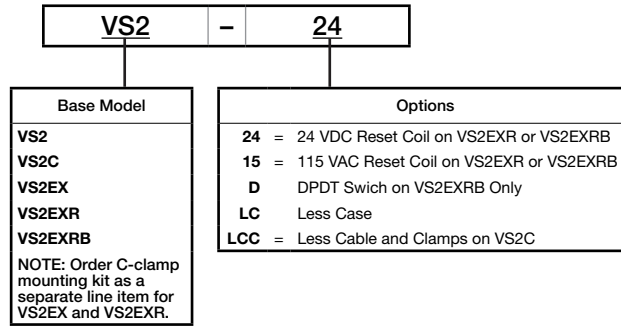

Service Part Number	Description	Notes
20000030	Movement assembly	VS2 and VS2C
20000031	Glass and gasket assembly	
20000032	Reset push button assembly	
20050021	Mounting clamp	VS2C
20000261	Cable clamp assembly (1 each)	
20050465	2-Conductor electrical cable, 45 feet (13.7 meters)	
20000137	5 clamps and 45 feet (13.7 meters) of cable	
20010091	Movement assembly	VS2EX
20050087	Cover	
00000309	Cover gasket	
20010090	Snap-switch and insulator kit (1 switch per kit) prior to Sept. 1, 1995.*	
20000288	Snap-switch and insulator kit (1 switch per kit) for models manufactured after Sept. 1, 1995.*	
20000289	C-clamp conversion mounting kit	VS2EXR
20000262	Movement assembly	
20050087	Cover	
00000309	Cover gasket	
20010090	Snap-switch and insulator kit (1 switch per kit) prior to Sept. 1, 1995.*	
20000288	Snap-switch and insulator kit (1 switch per kit) for models manufactured after Sept. 1, 1995.*	
20000049	Reset solenoid assembly (115 VAC)	VS2EXRB
20000234	Reset solenoid assembly (24 VDC)	
20000289	C-clamp conversion mounting kit	
20010090	Snap-switch and insulator kit (1 switch per kit) prior to Sept. 1, 1995.*	VS2EXRB
20000288	Snap-switch and insulator kit (1 switch per kit) for models manufactured after Sept. 1, 1995.*	
20000057	Inside snap-switch and insulator kit (1 switch per kit) for model VS2EXRB-D prior to Sept. 1, 1995.*	

\* Models with date 0895 and before use old switch. Dated 0995 and after, use straight snap-switch arm, no rollers.

## 2005年开始在中国经销Murphy摩菲仪表 - Murphy Instrument Distributor

信德迈科技（北京）有限公司 手机：13910962635 qq # 209136943

邮件：sales@cnmec.biz 网站：Http://www.cnmec.com